

# LOW CAPACITY SAMPLE COOLERS

## Model W9000

**THE WATERS EQUIPMENT 9000 SERIES SAMPLE COOLERS** are designed for small volume hot water samples. The efficient counterflow design provides cooling for samples up to 750°F and 3500 psig, and the simplicity provides maximum cooling at minimal cost.

### FEATURES

- **STAINLESS CONSTRUCTION:** All wetted parts are made of Stainless Steel to resist corrosion and to insure years of service at 100% duty cycle. Inconel coil model also available for greater corrosion resistance.
- **FORCED COUNTERFLOW:** Insures maximum thermal efficiency.
- **SIMPLE INSTALLATION:** Convenient mounting bracket provided.
- **COMPACT DESIGN:** Maximum heat transfer in a minimal space—only 17-1/4" high x 2-5/8" O.D.
- **ALL WELDED:** The all welded design assures that gasket leaks will be eliminated.



MODEL NUMBER	DESIGN PRESSURE		DESIGN TEMPERATURE		MATERIAL		HEAT TRANSFER SURFACE	WEIGHT
	COIL	SHELL	COIL	SHELL	COIL	SHELL		
W9000	3500 PSI	300 PSI	750°F	250°F	316SS	Stainless Steel	1.0 FT <sup>2</sup>	5 LBS.
W9050					INCONEL	Stainless Steel		

TEST PRESSURES: COIL – 6750 PSI; SHELL – 450 PSI

# Model W9000 or W9050 Low Capacity Sample Coolers

## PERFORMANCE DATA (APPROACH TEMPERATURES – °F) APPROACH TEMP. + COOLING WATER INLET TEMP. = FINAL SAMPLE TEMP.

### MODEL W9000 OR W9050

FLOW RATE CC/MIN	SAMPLE TEMPERATURE °F			SAMPLE PRESSURE DROP PSI
	300	500	700	
400	1	2	5	3
500	2	3	6	4
600	3	5	10	6
800	5	14	32	10

APPROACH TEMPERATURE °F

TYPICAL PERFORMANCE DATA BASED ON MAXIMUM COOLING WATER OF 3 GPM

## OUTLINE DIMENSIONS

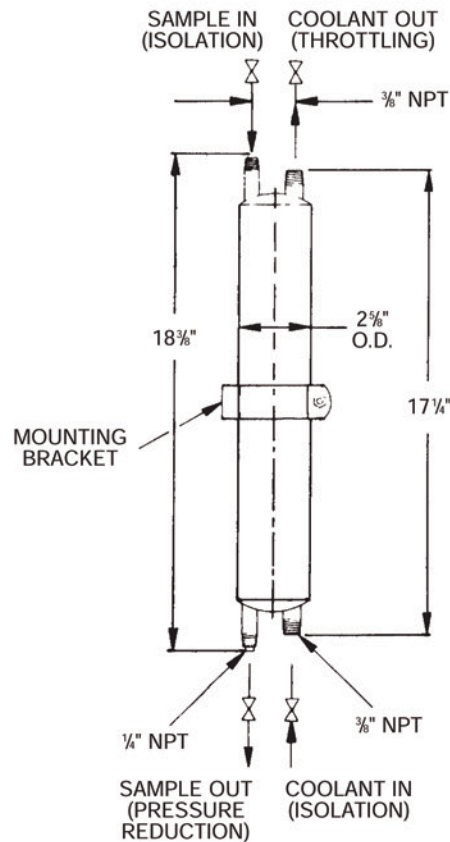

**THE WATERS EQUIPMENT EXPERTISE GOES BEYOND SAMPLE COOLERS.**

**WE ALSO DESIGN AND MANUFACTURE:**

Total Plant Water and Steam Analysis Systems • Sample Conditioning Modules • Pressure Reducers  
 Refillable Resin Cartridges • Hi-Temp Shut-Off Valves • Portable Samplers